

MATCON[®]

POWDERS, HANDLED.

IBC CLEANING MODULE

ELIMINATE CLEANING DOWNTIME.
RELIABLY.

Improve productive time by
washing off-line using a
Matcon IBC cleaning system.

www.matconibc.com



POWDERS, HANDLED.

Reduce system downtime and maximise production

Keep all the manufacturing process steps working whilst IBCs are cleaned off-line.

Because IBCs are taken off for cleaning, there is no need to halt manufacturing.

Simply bring in clean, fresh IBCs to keep the production line working to capacity.

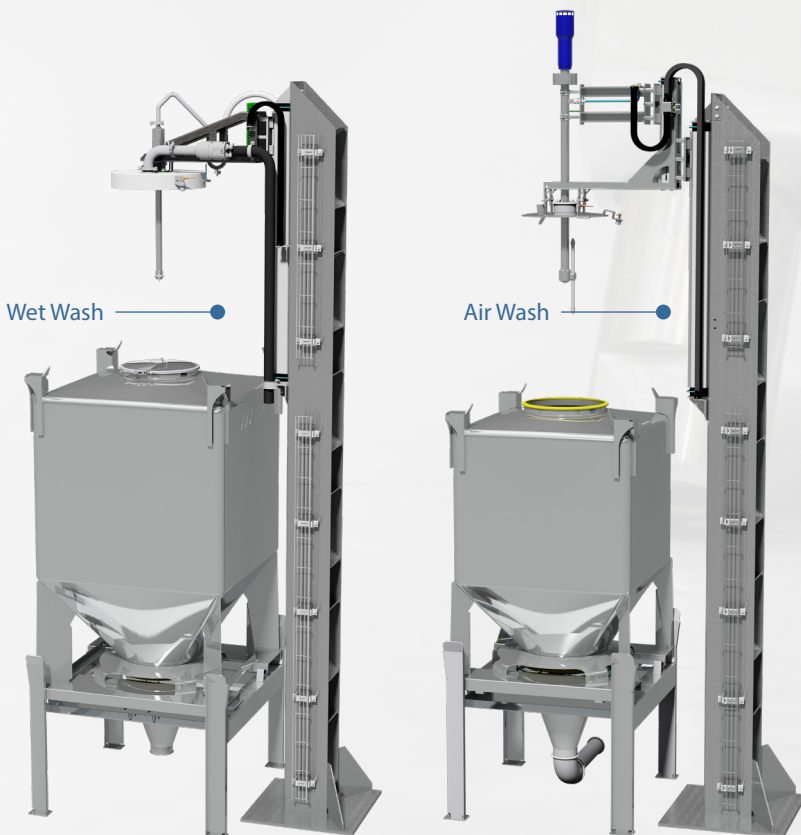

THE MATCON IBC CLEANING MODULE

Cleaning of IBCs off-line to reduce downtime

Systems range from simple manual wash lance to fully automatic operation

High pressure spray removes residual powders from the internal surfaces of the IBCs

Safe, repeatable wash sequences which can be validated for Regulatory Authorities



Eliminate the down-time for cleaning associated with traditional coupled systems.

High manufacturing efficiency rates as IBCs are cleaned off-line without causing mixer or manufacturing line down-time.

Simple IBC design enables easy cleaning of the internal surfaces with no risk of cross-contamination.

Air wash capability removes the risk of waterborne bacterial growth associated with using traditional water based systems.

Fully validatable process for approval by Regulatory Authorities.

IBC Cleaning options using either water or air systems

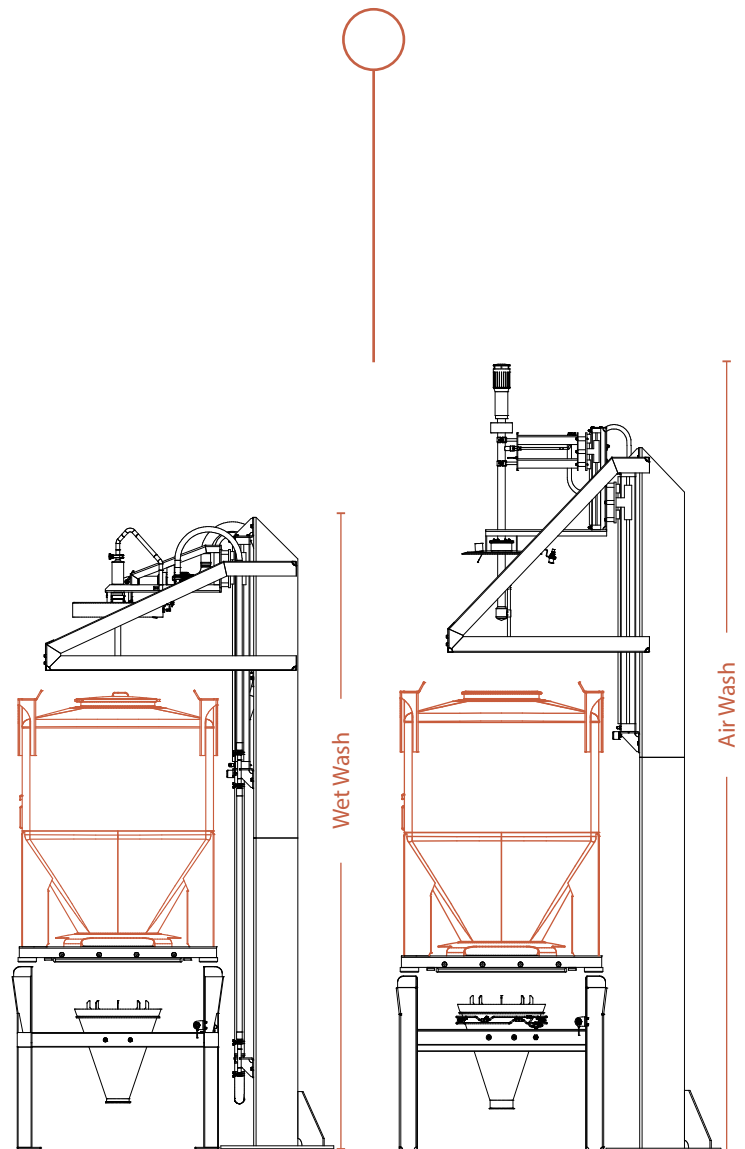

IBC Size	Wet Wash*	Air Wash*
1000	4040 mm	4542 mm
1500	4432 mm	4934 mm
2000	4873 mm	5375 mm
2500	5310 mm	5812 mm

*Approximate overall height measurements based on S11 IBC range.

MATCON®

POWDERS, HANDLED.

We specialise in providing complete materials handling solutions in the Food, Nutrition, Pharmaceutical and Chemical sectors.

We're not just an IBC provider, but a true partner helping you accomplish the right system for your needs.



THE POWDER HANDLING EXPERTS

www.matconibc.com



TEKEMAS

OUR SCANDINAVIAN PARTNER